

Numerical Simulation of Big Area Additive Manufacturing (3D Printing) of a Full Size Car

Challenge

Distortion and residual stress are common problems in structures manufactured using additive manufacturing (3D printing) technology. These problems lead to poor product quality, which often is only improved by trial and error, where the sensitivity of different manufacturing configurations to product quality is experimentally determined. Big Area Additive Manufacturing (BAAM) is a 3D printing process that utilizes Extrusion-Deposition (ED) to deposit a significant amount of material per unit time. Trial and error in this environment is uneconomical. What is needed is a computational tool, based on Finite Element Method, multi-scale progressive failure analysis, damage mechanics and fracture mechanics, to simulate the manufacturing process and identify material and process mechanisms, and to improve the quality of the build.

STEP 2: FE Model Genration

- ❖ .STL or G-Code, Layer-based Model
- ❖ Material Orientation from printer path

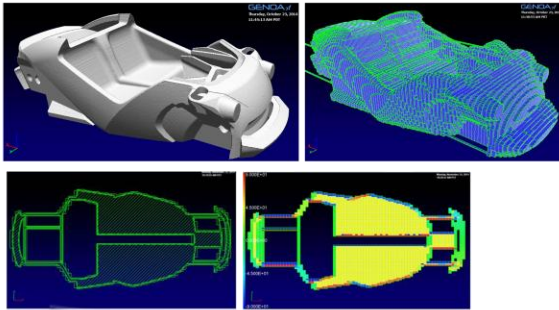

STEP 3: FE Thermal/Structural Validation

- ❖ Uncoupled Thermal Analysis
- ❖ Sequentially-Coupled Thermal/Structural
- ❖ Fully-Coupled Thermal/Structural

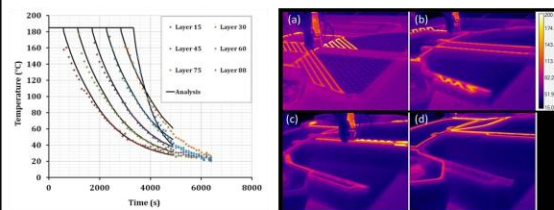

STEP 1: Multi-Scale Material Characterization

- ❖ Constituents material properties
- ❖ Orientation through thickness
- ❖ Effect of defects (void size, orientation)
- ❖ Inclusion shape and size

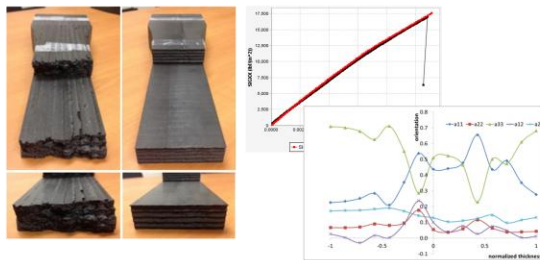

STEP 4: Process Simulation Prediction

- ❖ Delamination and damage from printing
- ❖ As-built part performance
- ❖ Probabilistic assessment

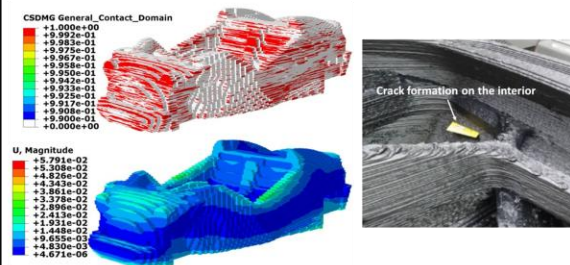

Solution

The first step in the pathway to a solution involved the determination of a material model that addressed the particular characteristics of extruded molten chopped carbon fiber reinforced acrylonitrile butadiene styrene (CF-ABS). This task was accomplished with the help of MCQ-Chopped and MCQ-Composites, which combined Nano- micro- and macro-mechanics with finite element and damage progression to calibrate the fiber orientation, fiber and matrix constituent properties, and matrix nonlinear behavior using flow and cross flow coupon tensile tests. In addition, MCQ Chopped was used to determine chopped fiber reinforced composite material properties, as a function of several manufacturing, geometric, and material variables, representative ply orientations for FEM analysis. It should be noted that the updated material model takes into consideration the effect of defects, the presence of voids and other imperfections.

The second step involved the generation of a structured mesh based on the printer path. Using GENOA 3DP Mesh and Model Generator, the software was able to read the G-code, extract the tool path and other critical data. Here, the tool path was threaded through the background grid and activated elements for the FEM model. The finished car mesh contained 419,759 elements, in which each layer contained rectangular elements and each finite element contained information about the orientation, time and printing parameters from the G-code traversal path and its residence time in the element. In this approach, orientation is used to determine anisotropic thermal and mechanical properties within each element. Once the material model was established and a structured mesh defined in grid space, it was now possible to pursue a coupled structural/thermal analysis simulation with GENOA 3DP software. In the

current effort, the selected approach involved a sequentially coupled thermal-stress analysis, which utilized temperature field data as input. However, before taking on the whole problem, the team investigated the thermal-structural behavior of a simple AM wall. Here, material thermal properties and the thermal portion of the coupled thermal-structural analysis was validated using measured temperatures of a relatively simple "wall model", manufactured using the BAAM process. The temperature profiles, within different layers were measured and used as comparison for the thermal validation step.

With confidence in the thermal structural solution secure, the team proceeded to simulate the ED build of the entire vehicle. The resulting analysis identified locations for crack initiation, based on the stress state of the printed part. These locations corresponded to

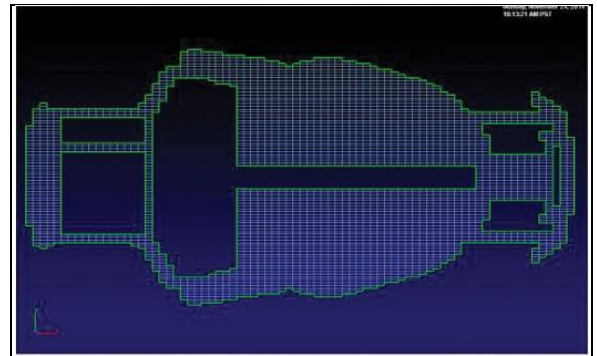

Structured mesh within a single layer

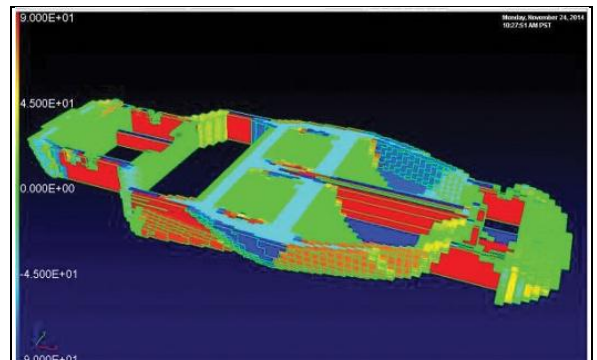

Element orientation information for partially built Strati vehicle.

empirically observed problem areas, such as the vehicle's front fender. GENOA 3DP multi-scale progressive failure analysis identified inter-bead crack formations resulting from thermal gradients, discontinuities, rotations and thermal stress.

Even though, lack of refinement in the FEM mesh resulted in stress concentration, the overall simulation provided valuable information on global stiffness, deformations and damages.

Beyond AM process simulation, GENOA 3DP framework was able to apply an external load to the virtual as-built Strati vehicle and assess the impact of service loading. Additional load cases were investigated for both as-designed and as-printed states. Mesh/Model generation was completed with a desktop computer running 4 Xeon processors and hosting 24 GB RAM. An FEM input deck generated by GENOA 3DP includes material orientations according to printer path, interaction behavior between the layers, solid sections based on defined orientations, and activation of elements sequence. A computer with 16 processors and 64 GB RAM was used for full solution, i.e. GENOA 3DP Simulation of the Strati vehicle AM build. The solution was performed by GENOA 3DP using ABAQUS as a solver and required 13 hours of explicit analysis.

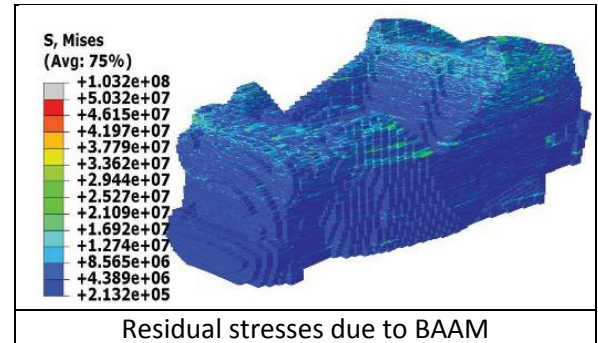

Key Highlights

Product: MCQ-Composites, GENOA, FEA Solver

Industry: Aerospace, Automotive, Manufacturing

Application: Simulation of Additive Manufacturing

Performance: Material and Process Sensitivities

Results/Conclusions/Benefits

- Tools simulated AM/ED process for a large complex structure.
- Developed tool provides a fully coupled thermo-mechanical solution of polymer additive manufacturing with reinforced plastics.
- Tool can be used to obtain material and process sensitivities with respect to product quality in an economically efficient manner compared to the trial and error philosophy.
- Linear elastic fracture mechanics analyzed delaminations between beads.
- The methodology identified problem areas in terms of high residual stress and crack formations in a time and cost efficient manner compared to trial and error methods.
- Methodology can support best practice to for determining product quality in terms of distortions, material damage and interface fracture due to manufacturing.

Reference

M. R. Talagani et al, "Numerical Simulation of Big Area Additive Manufacturing (3D Printing) of a Full Size Car," SAMPE Journal, Volume 51, No. 4, July/August 2015, pp 27-36.